

Typical Applications

The HMC342LC4 is ideal for:

- Point-to-Point Radios
- Point-to-Multi-Point Radios & VSAT
- Test Equipment & Sensors
- Military End-Use

Features

- Noise Figure: 3.5 dB
- Gain: 22 dB
- Single Positive Supply: +3.0 V @ 43 mA
- 50 Ohm Matched Input/Output
- RoHS Compliant 4x4 mm SMT Package

Functional Diagram

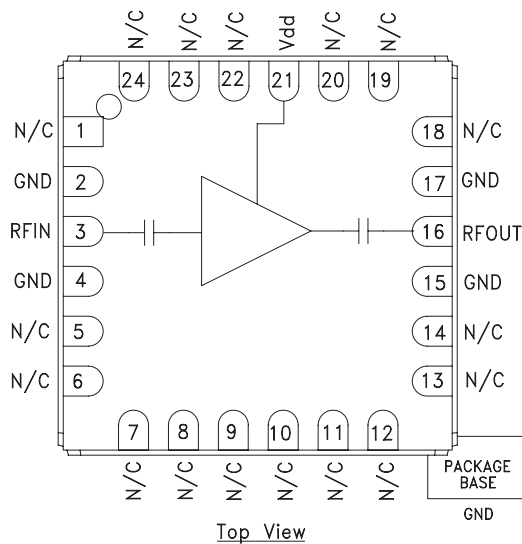

General Description

The HMC342LC4 is a GaAs PHEMT MMIC Low Noise Amplifier housed in a leadless 4x4 mm RoHS compliant SMT package. Operating from 13 to 25 GHz, the amplifier provides 22 dB of gain and +19 dBm of output IP3 from a single +3.0V supply. The low noise figure performance of 3.5 dB is ideal for receive and transmit pre-driver applications. The RF I/Os are DC blocked and matched to 50 Ohms for ease of use. The HMC342LC4 allows the use of surface mount manufacturing techniques and requires no external matching components.

Electrical Specifications, $T_A = +25^\circ\text{C}$, $V_{DD} = +3\text{V}$, $I_{DD} = 43\text{mA}$

| Parameter | Min. | Typ. | Max. | Min. | Typ. | Max. | Min. | Typ. | Max. | Units |
|--|---------|-------|-------|---------|-------|-------|---------|-------|-------|-------|
| Frequency Range | 13 - 18 | | | 18 - 22 | | | 22 - 25 | | | GHz |
| Gain | 19 | 22 | | 17 | 20 | | 16 | 19 | | dB |
| Gain Variation Over Temperature | | 0.025 | 0.035 | | 0.025 | 0.035 | | 0.025 | 0.035 | dB/°C |
| Noise Figure | | 3.5 | 4.0 | | 3.5 | 4.0 | | 3.5 | 4.5 | dB |
| Input Return Loss | | 15 | | | 15 | | | 10 | | dB |
| Output Return Loss | | 15 | | | 20 | | | 15 | | dB |
| Output Power for 1 dB Compression (P1dB) | | 7 | | | 8 | | | 9 | | dBm |
| Saturated Output Power (Psat) | | 9 | | | 11 | | | 11.5 | | dBm |
| Output Third Order Intercept (IP3) | | 16 | | | 19 | | | 20 | | dBm |
| Supply Current (Idd) (Vdd = +3V) | | 43 | | | 43 | | | 43 | | mA |



**GaAs PHEMT MMIC LOW NOISE
AMPLIFIER, 13 - 25 GHz**

Broadband Gain & Return Loss

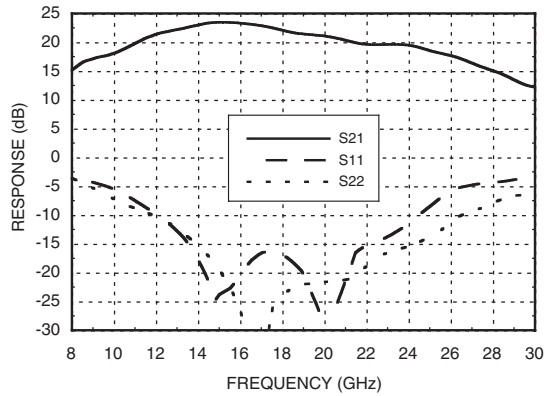

Gain vs. Temperature

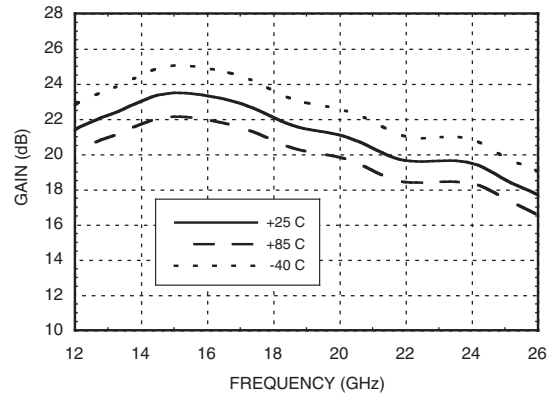

Input Return Loss vs. Temperature

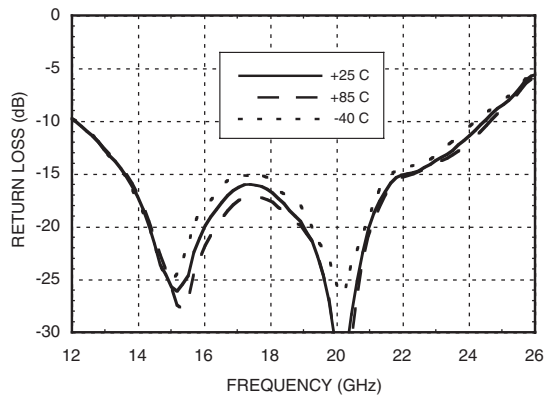

Output Return Loss vs. Temperature

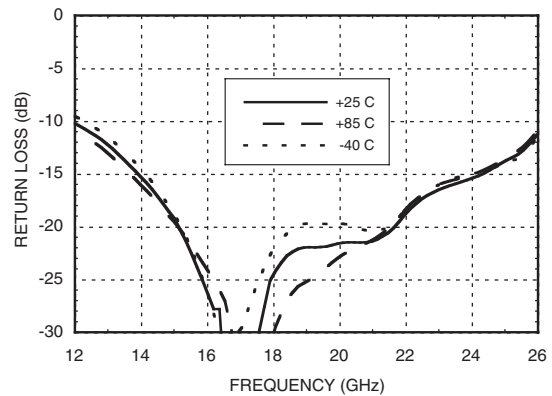

Noise Figure vs. Temperature

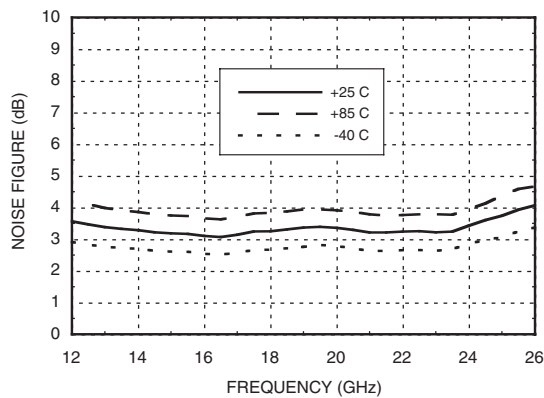

Output IP3 vs. Temperature

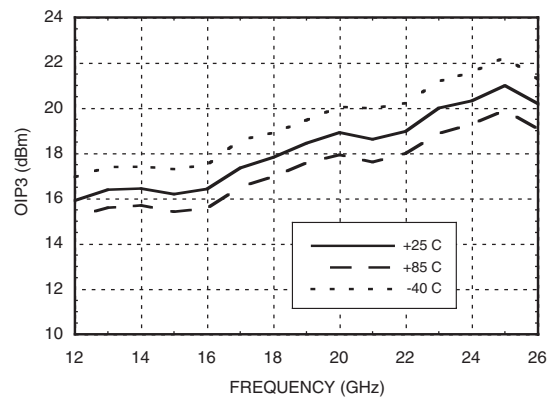



P1dB vs. Temperature

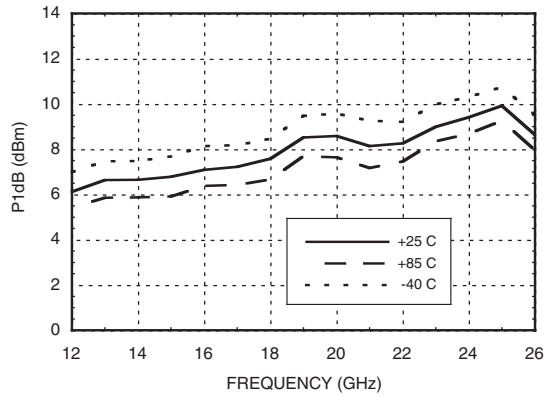

Psat vs. Temperature

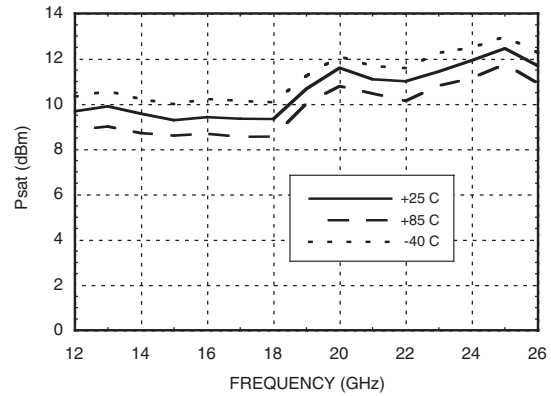

Power Compression @ 20 GHz

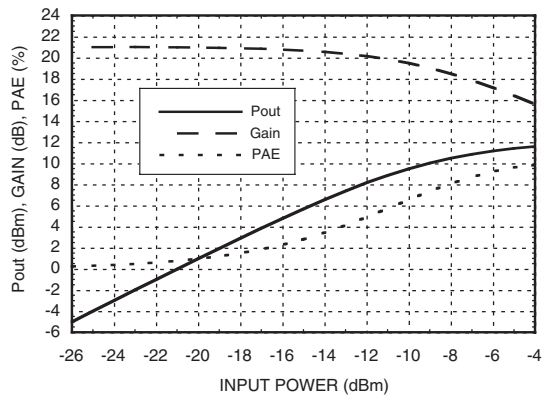

Reverse Isolation vs. Temperature

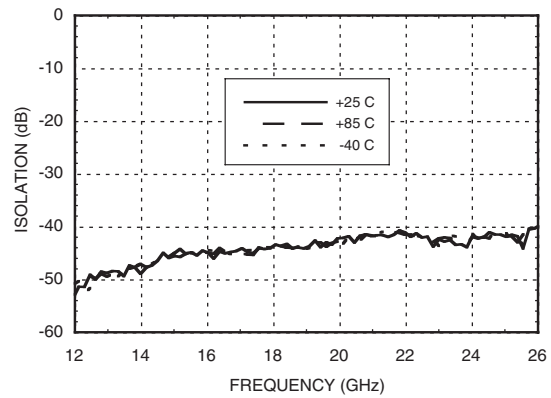

Gain, Power & Noise Figure vs. Supply Voltage @ 20 GHz

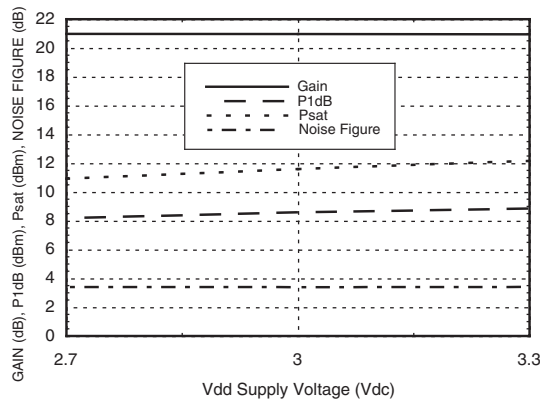



**GaAs PHEMT MMIC LOW NOISE
AMPLIFIER, 13 - 25 GHz**

Absolute Maximum Ratings

| | |
|--|----------------|
| Drain Bias Voltage (Vdd) | +5.5 Vdc |
| RF Input Power (RFIn)(Vdd = +3.0 Vdc) | 0 dBm |
| Channel Temperature | 175 °C |
| Continuous Pdiss (T= 85 °C) (derate 3.62 mW/°C above 85 °C) | 0.326 W |
| Thermal Resistance (channel to ground paddle) | 276 °C/W |
| Storage Temperature | -65 to +150 °C |
| Operating Temperature | -40 to +85 °C |

Typical Supply Current vs. Vdd

| Vdd (Vdc) | Idd (mA) |
|-----------|----------|
| +2.7 | 42 |
| +3.0 | 43 |
| +3.3 | 44 |

Note: Amplifier will operate over full voltage ranges shown above.

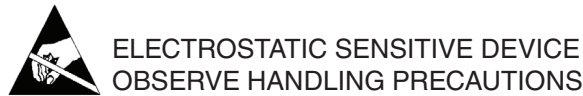

Outline Drawing

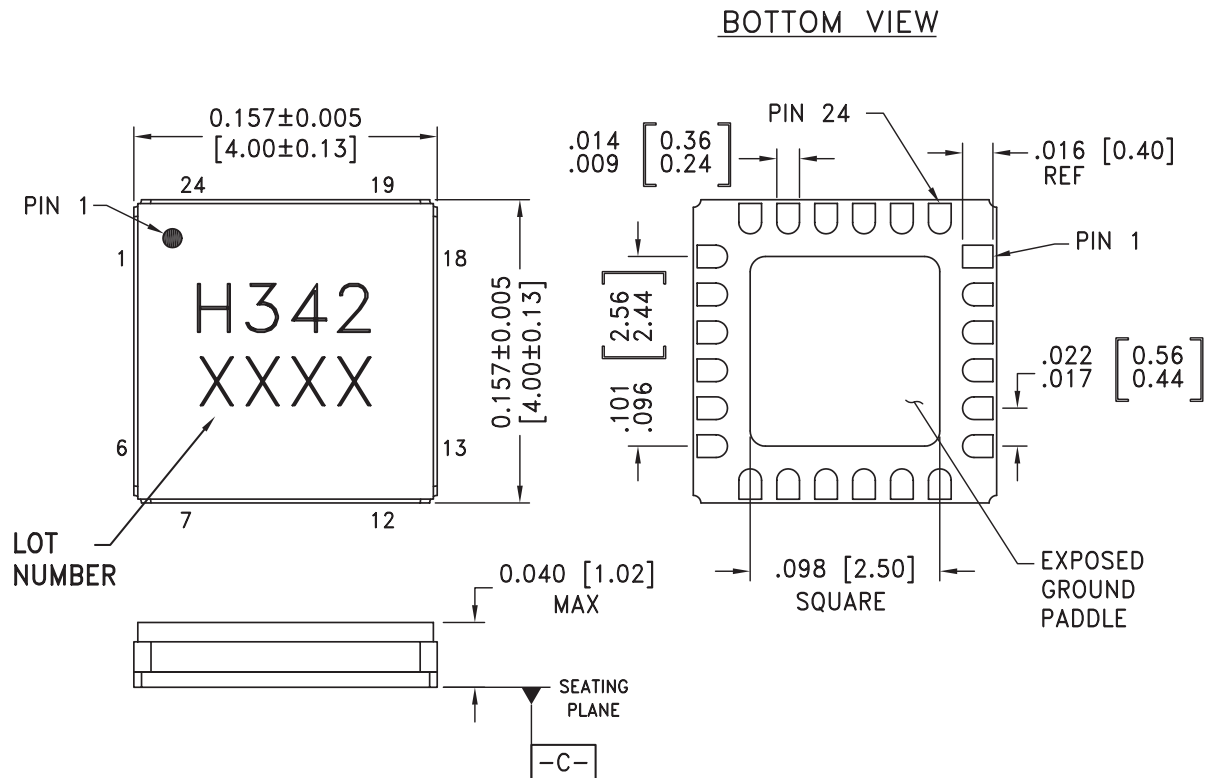

NOTES:

1. PACKAGE BODY MATERIAL: ALUMINA.
2. LEAD AND GROUND PADDLE PLATING: GOLD FLASH OVER NICKEL.
3. DIMENSIONS ARE IN INCHES (MILLIMETERS).
4. LEAD SPACING TOLERANCE IS NON-CUMULATIVE.
5. PACKAGE WARP SHALL NOT EXCEED 0.05MM DATUM -C-
6. ALL GROUND LEADS AND GROUND PADDLE MUST BE SOLDERED TO PCB RF GROUND.



Pin Descriptions

| Pin Number | Function | Description | Interface Schematic |
|--------------------------------|----------|--|---------------------|
| 1, 5 - 14, 18 - 20, 22 - 24 | N/C | No connection required. These pins may be connected to RF/DC ground without affecting performance. | |
| 2, 4, 15, 17 | GND | Package base has an exposed metal ground that must also be connected to RF/DC ground. | |
| 3 | RFIN | This pin is AC coupled and matched to 50 Ohms from 13 - 25 GHz. | |
| 16 | RFOUT | This pin is AC coupled and matched to 50 Ohms from 13 - 25 GHz. | |
| 21 | Vdd | Power Supply Voltage for the amplifier. External bypass capacitors of 100 pF, 1000pF, and 2.2 μF are required. | |

Application Circuit

| Component | Value |
|-----------|----------|
| C1 | 100 pF |
| C2 | 1,000 pF |
| C3 | 2.2 μF |

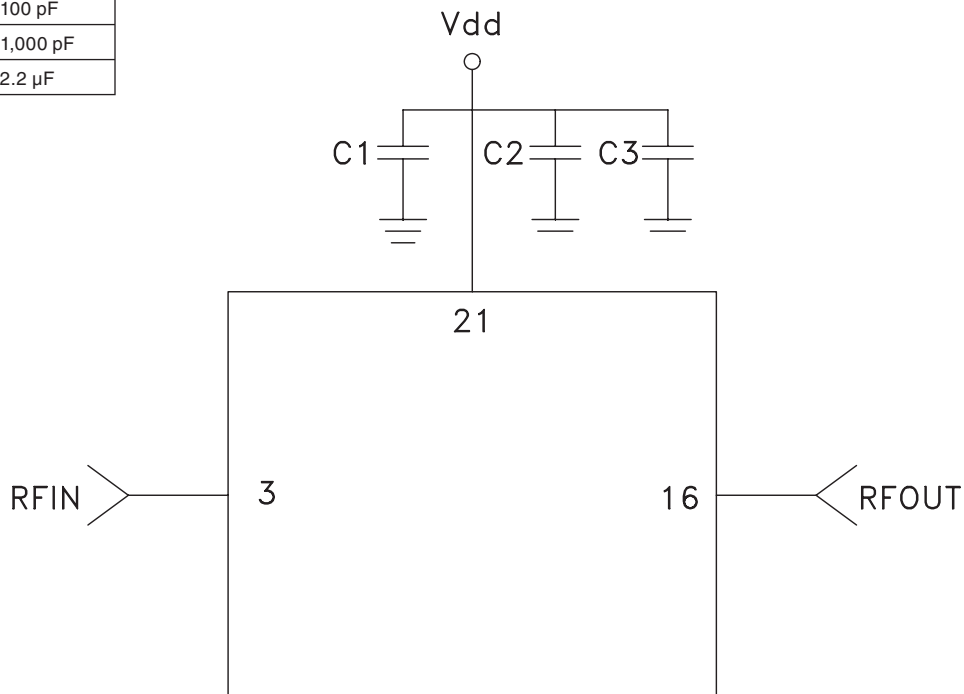

Evaluation PCB

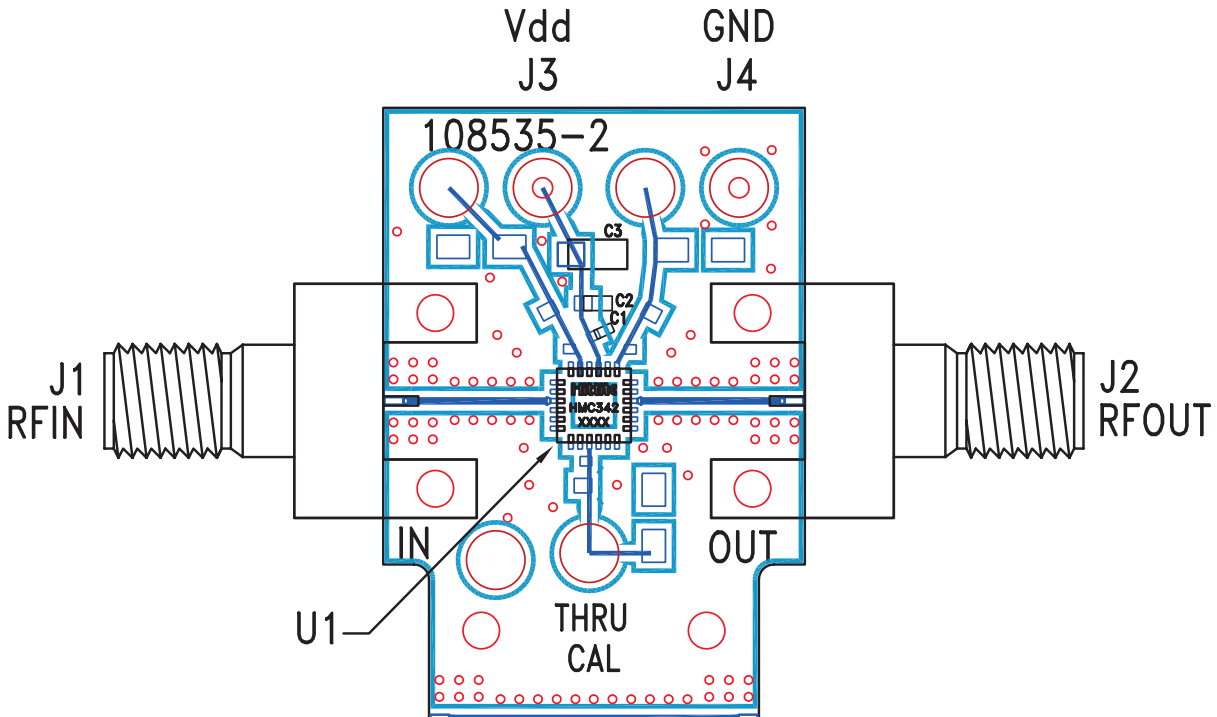

List of Materials for Evaluation PCB 110209 [1]

| Item | Description |
|---------|-------------------------------|
| J1, J2 | 2.92 mm PC mount K-connector |
| J3, J4 | DC Pin |
| C1 | 100 pF capacitor, 0402 pkg. |
| C2 | 1,000 pF Capacitor, 0603 pkg. |
| C3 | 2.2μF Capacitor, Tantalum |
| U1 | HMC342LC4 Amplifier |
| PCB [2] | 108535 Evaluation PCB |

[1] Reference this number when ordering complete evaluation PCB

[2] Circuit Board Material: Rogers 4350.

The circuit board used in this application should use RF circuit design techniques. Signal lines should have 50 ohm impedance while the package ground leads and exposed paddle should be connected directly to the ground plane similar to that shown. A sufficient number of VIA holes should be used to connect the top and bottom ground planes. The evaluation board should be mounted to an appropriate heat sink. The evaluation circuit board shown is available from Hittite upon request.